

# SKULLWORX

The Complete Helmet Electronics Unit

*Thanks for buying our self contained helmet electronics package for costume helmets!*

This product was put together after many hours of R&D using 'white armor' and is a great way to go for keeping everything self contained within a costume helmet where room allows. Please note that the instructions in this manual were specifically created for the widely seen science fiction 'white armor' costumes. The unit can be easily customized for other costume helmets but no instruction or support is provided for this.

Please read this entire manual before beginning installation. Double check that you have everything you need and that you UNDERSTAND these instructions before beginning the installation.

## ***Attention!***

***This unit is NOT for safety helmets intended to protect your head! Do NOT attempt to mount the electronics unit inside ANY safety helmet – it will greatly reduce the safety equipment's effectiveness in the event of an accident!***

Your continued reading beyond this point implies your agreement that you are installing this product and making any modifications as needed to your personal property under your own free will. Further, you will not hold SkullWorx.com or any associates accountable for damage done to your property or person due to, or during the course of, installing this product.

## I. Tools needed:

Drill\*  
1/8-inch drill bit\*

*\*As with anything power driven, hot or sharp, please use caution to avoid personal injury!*

## II. Part identification:



Pre-placed Industrial Strength Velcro is provided for your convenience. The Velcro connection method will allow for easy removal or repositioning of parts if needed. A bit of CA glue on the adhesive side of Velcro will help it stay attached in extreme heat, but this treatment should not be necessary for this unit.

### III. Preparation of your helmet:

Remove any items you currently have installed in your helmet except your hardhat liner or foam. (You may have to augment your foam if it is in the way). The entire bottom inner circumference of your helmet and the sides will need to be clear for the unit's installation.

### IV. Speaker installation:

The speaker(s) need to be installed first, as there will not be enough room to work once the unit is in place.

1. Disconnect the speakers from the wires coming out of the front of the unit and set them and the wire nuts aside. The wires are color coded and will go back together the same way they were shipped to you.

**Red wires and striped wire go together**

**Black wires and clear wire go together**

2. **For E4 units:**

If you've not done so already, drill a 1/8th inch anchor hole in the center of each aerator location for the mounting screw. Drill a second hole to the side of the anchor hole for the speaker wires. Thread the speaker wires through the side hole, and install both assemblies to your helmet using the provided nut.



old and new holes inside helmet



screw and wire threaded through holes

#### **For E3 units:**

Print out the last page of this manual and cut out the templates for centering the mounting holes first. Once the center is noted, drill a 1/8th inch anchor hole for the mounting screw. Drill a second hole to the side of the anchor hole for the speaker wires. Thread the speaker wires through the side hole, and install both assemblies to your helmet using the provided washer and nut. If necessary, the flare portion of each 'aerator' can be sanded down or trimmed as needed to fit.

## V. Placing the unit

Carefully insert the entire electronics unit into your helmet. It should be installed with the fans and speaker wire lead to the front. If you require less tubing, you can 'telescope' it to adjust the size. You can 'anchor' the size by cutting a small hole in the tubing where the overlap occurs and threading a zip tie through the holes, but this is not necessary.



Front (fans)

Note: image does not show easy reach power switches – they should be facing out.



Rear (tubing can be telescoped to allow for resizing)

## VI. Securing the battery boxes

1. Check for clearance while wearing the helmet, then peel the backing strips off the pre-attached Velcro. The boxes can be placed where you like, but a suggested position is vertically just below where your ears are. Though it should not be necessary with this unit, a bit of CA glue on the adhesive side can help keep the Velcro secured in extreme heat conditions.

## VII. Securing the Amplifier box

1. Check for clearance while wearing the helmet, then secure the amplifier box by peeling the backing strip off the pre attached Velcro and pressing it into place toward the rear of the helmet. Though it should not be necessary with this unit, a bit of CA glue on the adhesive side can help keep the Velcro secured in extreme heat conditions.

## VIII. Connecting the speakers

1. Connect the remaining speaker wires to the speaker wires coming out of the split loom tubing. Remember to match up the colors properly -  
**Red wires and striped wire go together**  
**Black wires and clear wire go together**
2. Carefully tuck the wires and wire nuts into the split loom tubing to hide them.

## XI. Securing the fans

1. Mount the fans in an upright position using the pre attached Velcro. Alternately, remove the Velcro and place the fans on the aerator screws, using the mounting holes on the fan casings. Fill the holes with hot glue, if available, to secure them. **Don't use CA glue for this.** Using CA glue for this will make it impossible to remove the fans, screws, or aerators should the need ever arise.
2. Carefully tuck any wires into the split loom tubing to hide them.
3. Test the fans to ensure they aren't rubbing against anything and adjust as necessary.

## X. Securing the microphone and earpieces

1. Place the microphone inside the helmet where you think it will work best using the pre attached Velcro. You can reposition it as needed.
2. Wear the helmet and try a few different positions with the microphone. It should just brush the corner of your mouth and the earpiece should be fairly close to your ear. When you find the best position for you, press the Velcro firmly onto the helmet to secure it well. Again, a bit of CA glue on the adhesive side can help keep the Velcro secured in extreme heat conditions.
3. Mount the second earpiece on the opposite side close to where your ear will be when wearing the helmet.
4. Carefully tuck any wires into the split loom tubing to hide them.
5. Once you have the microphone mounted, insert your 9 volt batteries and power on your PA using the easy reach power switch. Increase the volume until feedback occurs while NOT wearing the helmet, and then reduce the volume until the feedback stops. This is the optimal volume for your helmet's inner acoustics. From this point on, you can turn off/on the PA power using the easy reach switch and should not have to re-adjust your volume.

## XI. Fine tuning and tips

- Some **feedback** (high pitched whine) is normal and is unavoidable in the extremely close confines of your helmet – even with anti-feedback circuitry. If you experience feedback, turn down the volume on the amplifier little by little until it stops. Once you've fine tuned your amplifier, use the easy reach power switch to power on/off.
- **Feedback** when donning and removing the helmet is normal – you're changing the acoustics inside the helmet and it may be unavoidable.
- **Intermittent feedback** can be caused by variables outside of the helmet such as tiled hallways, confined spaces, or even an object directly in front of the speakers. To stop feedback that occurs during these times or while wearing the helmet in conditions where it is undesirable to remove it to make volume adjustments, suck the microphone into your mouth briefly to break the feedback loop (try not to get it too wet), or remove yourself from the environment.
- To make a “**static burst**”, click with your mouth like calling a horse and blow onto the microphone making a Pfffft sound when you begin or finish talking as you see fit. Field testing has proven that when compared side by side with a static burst board that the mouth method sounds the same, if not better depending upon the skill and consistency of the user.
- If you prefer to use electronic circuitry for the automation of a **static burst**, one of these units can be utilized with your SkullWorx unit. If your static burst unit includes an amp already, (like the **RomFX** unit) you may experience feedback or other difficulties. No support is provided for **RomFX**.
- **Hyperdyne's Trooper Voice Amp** is verified to be compatible with SkullWorx but requires a powered microphone. Remove the SkullWorx microphone and plug the Hyperdyne output into the SkullWorx microphone jack. Adjust volumes as needed fine tuning the SkullWorx unit's volume to your helmet first. Slowly raise the volume on the static burst unit until you're satisfied with the results. Other static burst solutions are not confirmed to work with SkullWorx.
- **No sound or fans not running?** Check that:
  - your batteries are good
  - you have batteries in each box
  - all easy reach switches are in ON position
  - amplifier box volume is turned up (no black mark showing)
  - microphone plug is inserted into the proper jack
  - the speakers are properly (re)connected (RED to striped wire, BLACK to clear wire)

- **External hearing:** Skullworx is set up for easy installation of external hearing using a sound amplifier unit like 'Spy Ear' (google it), 'Listen Up!', Gossip Gizmo (RadioShack), or other similar binaural hearing amplification product.

To install:

Remove the belt clip and cover screw on your selected sound amplifier unit.

Open the cover and carefully remove the microphone from the case. It may be surrounded with a neoprene-like sound dampening material. Keep this material intact.

Cut a small notch in the case for the microphone wires to pass through, and then replace case cover and clip, leaving the microphone on the outside.

Carefully mount the microphone at one of your frown vent cutouts using a bit of hot melt glue,

Mount the case to a spot in the front helmet area using Velcro for easy removal and replacement of battery as needed.

Connect the green Skullworx plug into the hearing amplifier's jack.

Power on the hearing amplifier and carefully adjust the volume to a comfortable level.

Mark the volume wheel with a permanent marker to help you quickly adjust the volume in the future.

**CAUTION: HEARING DAMAGE CAN OCCUR with increased volume on any hearing amplifier – use common sense and protect your hearing.**

## X. E3 Speaker Mounting Template

**Be sure your printer's scale settings are set to 100% before printing this page.**

**Final outer diameter of template on printed copy should be 1-3/8<sup>th</sup> inches (3.5cm)**

1. Print this page and cut out the circles.
2. Using a sharp pencil, poke a small hole through the center of each template.
3. Place each template into the recessed areas of your helmet.
4. If the template doesn't quite fit, note the areas on the template where sanding / trimming of the speaker unit will be needed.
5. With the template centered in place on the helmet, use a sharp pencil to mark the center point for drilling the mounting hole.
6. Drill the centered mounting hole using a 1/8th drill bit.
7. Drill a second hole for the speaker wires at least 1/4" away from the centered mounting hole.
8. Remove the nut and washer from each speaker unit and test fit each speaker unit.
9. Sand/trim parts as needed. Use the marks you previously made on the paper templates, if any. **BE SURE TEMPLATES ARE ORIENTED CORRECTLY BEFORE BEGINNING ANY SANDING OR TRIMMING OF SPEAKER UNITS (Left, Right, Top, Bottom, This side to bottom of 'aerator')**.
10. Insert the mounting screw through the hole and attach the washer and nut, but leave slightly loose.
11. Rotate each 'aerator' so that the longer sides of the rectangles in the screen are vertically oriented and symmetrical to each other and finger tighten nut to mounting screw to secure position.

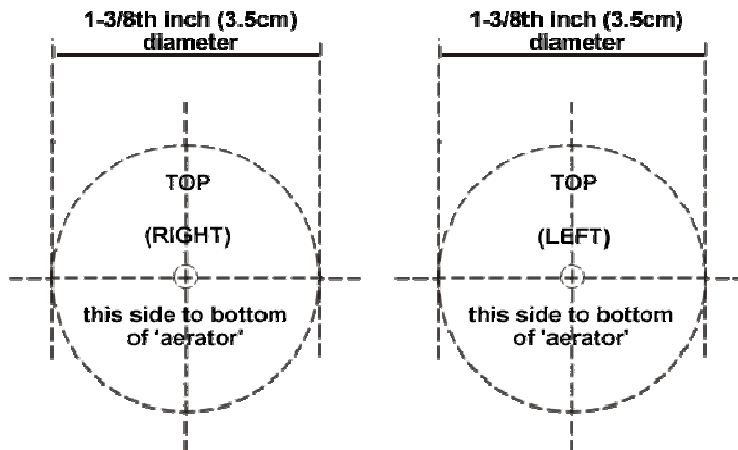

**SKULLWORX**  
The Complete Helmet Electronics Unit

**SkullWorx.com**

*All content and graphics © 2004 by SkullWorx.com*

*All products and intellectual ideas for self contained helmet electronics unit © 2003 by SkullWorks.com*

*Not affiliated with Lucas Film Ltd.*